

LED L-858B Distance Remaining Signs

Size 4, Internally Illuminated

Installation Manual

Document Number

96A0377, 18 August 2008,
Rev. B , 17 November 2008

ETL Certified to FAA Specification

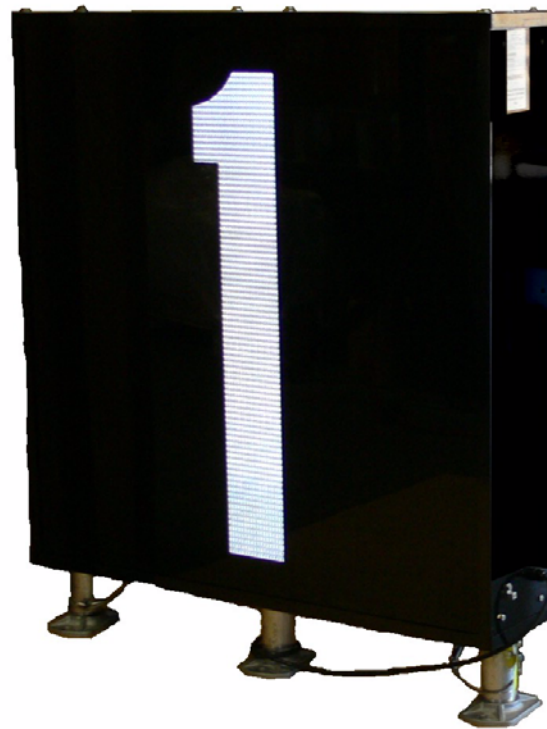

Siemens Airfield Solutions

P.O. Box 30829 Tel. (614) 861-1304
977 Gahanna Parkway Fax. (614) 864-2069
Columbus, OH 43230

Copyright © 2008 Siemens Airfield Solutions. All rights reserved

Siemens Airfield Solutions

*The innovative
approach™*

History of Change*Disclaimer*

1.0 History of Change

PAGE	REV	DESCRIPTION	EC NO.	CHECKED	APPROVED	DATE
All	A	Released Manual	2034	SA	GM	8/20/08
1-3	B	Warranty	2117	JR	GM	11/17/08

1.1 Disclaimer

This manual could contain technical inaccuracies or typographical errors. Siemens Airfield Solutions reserves the right to revise this manual from time to time in the contents thereof without obligation of Siemens Airfield Solutions to notify any person of such revision or change.

Details and values given in this manual have been compiled with care. They are not binding, however, and Siemens Airfield Solutions disclaims any liability for damages or detriments suffered as a result of reliance on the information given herein or the use of products, processes or equipment to which this manual refers. No warranty is made that the use of the information or of the products, processes or equipment to which this manual refers will not infringe any third party's patents or rights.

1.2 Warranties

Products of Siemens Airfield Solutions manufacturer are guaranteed against mechanical, electrical, and physical defects (excluding lamps) for a period of one year from the date of installation or a maximum of two years from the date of shipment and are guaranteed to be merchantable and fit for the ordinary purposes for which such products are made.

Siemens Airfield Solutions will correct by repair or replacement, at its option, equipment or parts which fail because of mechanical, electrical or physical defects, provided that the goods have been properly handled and stored prior to installation, properly installed and properly operated after installation, and provided further that Buyer gives Siemens Airfield Solutions written notice of such defects after delivery of the goods to Buyer.

This sign is manufactured under AC/150-5345-44H, *Specification for Runway and Taxiway Signs*, and warranted for 2 years after the installation date. Any defects in material or workmanship will be corrected or the sign replaced by the manufacturer at no cost to the airport owner.

Siemens Airfield Solutions reserves the right to examine goods upon which a claim is made. Said goods must be presented in the same condition as when the defect therein was discovered. Siemens Airfield Solutions further reserves the right to require the return of such goods to establish any claim.

Siemens Airfield Solutions's obligation under this guarantee is limited to making repair or replacement within a reasonable time after receipt of such written notice and does not include any other costs such as the cost of removal of defective part, installation of repaired product, labor or consequential damages of any kind, the exclusive remedy being to require such new parts to be furnished.

Siemens Airfield Solutions's liability under no circumstances will exceed the contract price of goods claimed to be defective. Any returns under this guarantee are to be on a transportation charges prepaid

History of Change

Trademarks

basis. For products not manufactured by, but sold by Siemens Airfield Solutions, warranty is limited to that extended by the original manufacturer.

This is Siemens Airfield Solutions's sole guarantee and warranty with respect to the goods; there are no express warranties or warranties of fitness for any particular purpose or any implied warranties of fitness for any particular purpose or any implied warranties other than those made expressly herein. All such warranties being expressly disclaimed.

1.3 Trademarks

General notice: other product names used here are for identification purposes only and may be trademarks of their respective companies.

1.4 Proprietary Information

This information carrier contains proprietary information, which shall not be used for other purposes than those for which it has been released, nor be reproduced or disclosed to third parties without the prior written consent of Siemens Airfield Solutions.

No part of this publication may be reproduced, stored in a retrieval system, or transmitted in any form or by any means, mechanical, photocopy, recording, or otherwise, without the prior written permission of Siemens Airfield Solutions. No patent liability is assumed with respect to the use of the information contained herein. Neither is any liability assumed for damages resulting from the use of the information contained herein.

Siemens Airfield Solutions shall not be liable to the purchaser of this product or third parties for damages, losses, costs, or expenses incurred by purchaser or third parties as a result of accident, misuse, or abuse of this product or unauthorized modifications, repairs, or alterations to this product. Siemens Airfield Solutions shall not be liable against any damages arising from the use of any options or parts other than those designated as approved products.

Copyright © 2008 by Siemens Airfield Solutions. All rights reserved.

1.0 Safety

1.1 Introduction

This section contains general safety instructions for installing and using Siemens Airfield Solutions equipment. Some safety instructions may not apply to the equipment in this manual. Task- and equipment-specific warnings are included in other sections of this manual where appropriate.

Carefully read and observe all safety instructions in this manual, which alert you to safety hazards and conditions that may result in personal injury, death or property and equipment damage and are accompanied by the symbol shown below.



WARNING

Failure to observe a warning may result in personal injury, death or equipment damage.

CAUTION

Failure to observe a caution may result in equipment damage.

1.2 To use this equipment safely:



WARNING

Read installation instructions in their entirety before starting installation.

- Refer to the FAA Advisory Circular AC 150/5340-26, Maintenance of Airport Visual Aids Facilities, for instructions on safety precautions.
 - Observe all safety regulations. To avoid injuries, always disconnect power before making any wiring connections or touching any parts. Refer to FAA Advisory Circular AC 150/5340-26.
 - Become familiar with the general safety instructions in this section of the manual before installing, operating, maintaining or repairing this equipment.
 - Read and carefully follow the instructions throughout this manual for performing specific tasks and working with specific equipment.
 - Make this manual available to personnel installing, operating, maintaining or repairing this equipment.
 - Follow all applicable safety procedures required by your company, industry standards and government or other regulatory agencies.
 - Route electrical wiring along a protected path. Make sure they will not be damaged by moving equipment.
 - Protect components from damage, wear, and harsh environment conditions.
 - Allow ample room for maintenance, panel accessibility, and cover removal.
 - Protect equipment with safety devices as specified by applicable safety regulations.
 - If safety devices must be removed for installation, install them immediately after the work is completed and check them for proper functioning prior to returning power to the circuit.
-

1.2.1 Additional Reference Materials:

- NFPA 70B, Electrical Equipment Maintenance
- NFPA 70E, Electrical Safety Requirements for Employee Workplaces
- ANSI/NFPA 79, Electrical Standards for Metalworking Machine Tools
- OSHA 29 CFR, Part 1910, Occupational Health and Safety Standards
- National and local electrical codes and standards.

Safety

Qualified Personnel

1.3 Qualified Personnel

The term **qualified personnel** is defined here as individuals who thoroughly understand the equipment and its safe operation, maintenance and repair. Qualified personnel are physically capable of performing the required tasks, familiar with all relevant safety rules and regulations and have been trained to safely install, operate, maintain and repair the equipment. It is the responsibility of the company operating this equipment to ensure that its personnel meet these requirements.

Always use required personal protective equipment (PPE) and follow safe electrical work practices. See 1.1, and 1.1.1 above.

1.4 Intended Use



WARNING

Using this equipment in ways other than described in this manual may result in personal injury, death or property and equipment damage. Use this equipment only as described in this manual.

Siemens Airfield Solutions cannot be responsible for injuries or damages resulting from nonstandard, unintended applications of its equipment. This equipment is designed and intended only for the purpose described in this manual. Uses not described in this manual are considered unintended uses and may result in serious personal injury, death or property and equipment damage. Unintended uses may result from taking the following actions:

- Making changes to equipment that are not recommended or described in this manual or using parts that are not genuine Siemens Airfield Solutions replacement parts
- Failing to make sure that auxiliary equipment complies with approval-agency requirements, local codes and all applicable safety standards
- Using materials or auxiliary equipment that are inappropriate or incompatible with Siemens Airfield Solutions equipment
- Allowing unqualified personnel to perform any task

1.5 Storage



CAUTION

If equipment is to be stored prior to installation, it must be protected from the weather and kept free of condensation and dust.

Failure to follow this instruction can result in injury or equipment damage.

1.6 Operation



WARNING

- Only qualified personnel, physically capable of operating the equipment and with no impairments in their judgment or reaction times, should operate this equipment.
- Read all system component manuals before operating this equipment. A thorough understanding of system components and their operation will help you operate the system safely and efficiently.
- Before starting this equipment, check all safety interlocks, fire-detection systems, and protective devices such as panels and covers. Make sure all devices are fully functional. Do not operate the system if these devices are not working properly. Do not deactivate or bypass automatic safety interlocks or locked-out electrical disconnects or pneumatic valves.
- Never operate equipment with a known malfunction.
- Do not attempt to operate or service electrical equipment if standing water is present.
- Use this equipment only in the environments for which it is rated. Do not operate this equipment in humid, flammable, or explosive environments unless it has been rated for safe operation in these environments.
- Never touch exposed electrical connections on equipment while the power is ON.

1.7 Material Handling Precautions



CAUTION

This equipment may contain electrostatic sensitive devices.

- Protect from electrostatic discharge.
- Electronic modules and components should be touched only when this is unavoidable e.g. soldering, replacement.
- Before touching any component of the cabinet you should bring your body to the same potential as the cabinet by touching a conductive earthed part of the cabinet.
- Electronic modules or components must not be brought in contact with highly insulating materials such as plastic sheets, synthetic fibre clothing. They must be laid down on conductive surfaces.
- The tip of the soldering iron must be grounded.
- Electronic modules and components must be stored and transported in conductive packing.

1.8 Action in the Event of a System or Component Malfunction



WARNING

- Do not operate a system that contains malfunctioning components. If a component malfunctions, turn the system OFF immediately.
- Disconnect and lock out electrical power.
- Allow only qualified personnel to make repairs. Repair or replace the malfunctioning component according to instructions provided in its manual.

Safety

Maintenance and Repair

1.9 Maintenance and Repair



WARNING

Allow only qualified personnel to perform maintenance, troubleshooting, and repair tasks.

- Only persons who are properly trained and familiar with Siemens Airfield Solutions equipment are permitted to service this equipment.
 - Disconnect and lock out electrical power.
 - Always use safety devices when working on this equipment.
 - Follow the recommended maintenance procedures in your equipment manuals.
 - Do not service or adjust any equipment unless another person trained in first aid and CPR is present.
 - Connect all disconnected equipment ground cables and wires after servicing equipment. Ground all conductive equipment.
 - Use only approved Siemens Airfield Solutions replacement parts. Using unapproved parts or making unapproved modifications to equipment may void agency approvals and create safety hazards.
 - Check interlock systems periodically to ensure their effectiveness.
 - Do not attempt to service electrical equipment if standing water is present. Use caution when servicing electrical equipment in a high-humidity environment.
 - Use tools with insulated handles when working with electrical equipment.
-

1.0 History of Change	1-3
1.1 Disclaimer	1-3
1.2 Warranties	1-3
1.3 Trademarks	1-4
1.4 Proprietary Information	1-4
1.0 Safety	1-5
1.1 Introduction	1-5
1.2 To use this equipment safely:	1-5
1.2.1 Additional Reference Materials:	1-5
1.3 Qualified Personnel	1-6
1.4 Intended Use	1-6
1.5 Storage	1-6
1.6 Operation	1-7
1.7 Material Handling Precautions	1-7
1.8 Action in the Event of a System or Component Malfunction	1-7
1.9 Maintenance and Repair	1-8
2.0 Introduction	2-1
2.1 L-858B Introduction	2-1
2.1.1 Compliance with Standards	2-1
2.1.2 Uses	2-1
2.1.3 Sign Legends	2-1
2.1.4 Features	2-1
2.1.5 Operating Conditions	2-1
2.1.6 Dimensions	2-2
Table 2.1 : Sign Heights	2-2
Table 2.2 : Sign Lengths - Inches (Centimeters)	2-2
Figure 2.1 : L-858 Sign Dimensions (Size 4/One-Module)	2-2
Table 2.3 : L-858 Size 4 Sign Dimensions	2-2
2.1.7 Construction	2-2
2.1.8 Electrical Supply	2-3
Table 2.4 : Style No. Power Source	2-3
2.1.9 Sign Load and Transformer Requirements	2-3
2.1.10 Spare Components	2-3
2.1.11 Packaging Data	2-3
3.0 Installation	3-1
Figure 3.1 : Remote/Direct Mounting	3-1
3.1 Unpacking	3-1
3.2 Cord Set Installation	3-2
3.2.1 Cord Set Installation Reference Number	3-2
Figure 3.2 : Cord set Location #1 (Non-typical)	3-2
Table 3.1 : Cord set Location #1 Parts	3-2
Figure 3.3 : Figure 3-2 Cord set Location #2 (Non-typical)	3-3
Table 3.2 : Cord set Location #2 Parts	3-3
Table 3.3 : Flexible Conduit Connectors	3-3
Figure 3.4 : Cord set Location #3 (Standard)	3-4
Table 3.4 : Cord set Location #3 Parts	3-4
Figure 3.5 : Cord set Location #4 (Standard)	3-5
Table 3.5 : Cord set Location #4 Parts	3-5
3.2.2 Cord set and Extension Cords	3-6
Figure 3.6 : L-823 Cord set and Extension Cords	3-6

Table 3.6. : Cord set and Extension Cord Length	3-6
Table 3.7. : Cord set and Extension Cord Parts	3-6
3.3 General Guidelines	3-7
3.3.1 Overall Mounting Height	3-7
3.3.2 Sign Orientation	3-7
3.3.3 Sign Distance from Pavement Edge	3-7
Table 3.8. : Recommended Sign Distance from Pavement Edge	3-7
3.3.4 Sign Installation on Concrete Pad	3-7
Figure 3.7. : Mode 1 and 2 Frangible Couplings	3-8
Figure 3.8. : Mode 3 Frangible Couplings	3-8
3.3.5 Sign Mounting	3-9
Figure 3.9. : Sign Frangible Coupling	3-9
3.3.6 Wiring	3-10
3.3.7 Earth Ground Lug	3-10
3.3.8 Optional Tethers	3-10
Figure 3.10. : Installing Optional Tether	3-10
Figure 3.11. : Wiring Diagram	3-11
4.0 Maintenance	4-1
Table 4.1. : L-858 Taxiway and Runway Sign Maintenance	4-1
4.1 Replacing the Power Supply	4-2
4.1.1 Wiring the Power Supply	4-2
Figure 4.1. : The LED Power Supply	4-2
4.2 Replacing an LED Panel	4-3
Figure 4.2. : Sign Panel Interior - Single and Double Channel Shown	4-3
4.3 Troubleshooting	4-4
5.0 Parts/Ordering Codes	5-1
5.1 Parts and Ordering Codes	5-2
Figure 5.1. :	5-3
Figure 5.2. :	5-4

2.0 Introduction



WARNING

Read the instructions in their entirety before starting installation.

2.1 L-858B Introduction

2.1.1 Compliance with Standards

- FAA: L-858B AC 150/5345-44 (Current Edition)
- FAA Engineering Brief No. 67 "Light Sources other than Incandescent and Xenon for Airport Lighting Obstruction Lighting Fixtures." ETL Certified

2.1.2 Uses

L-858B—Runway Distance Remaining Sign

The L-858B is used at 1,000-foot intervals adjacent to the runway edge in order to provide runway distance remaining information to pilots during takeoff and landing operations.

2.1.3 Sign Legends

Type	Purpose	Legend Color	Background Color
L-858B	Runway Distance Remaining	White	Black

2.1.4 Features

- Virtually eliminates runway shutdowns due to Distance Remaining Sign maintenance
- Direct replacement for existing sign
- Creates a highly uniform distribution of light, eliminating hot spots and shadows
- Can be powered from either a ferroresonant or thyristor type CCR
- Operates on 3-step, 5-step and 5.5A series circuits
- Reduces re-lamping expenses and on-going maintenance costs
- Improved safety — low, regulated DC voltage inside sign

2.1.5 Operating Conditions

Temperature: -40°F to +131°F (-40°C to +55°C)

Humidity: 0 to 100%

Wind: Withstands wind velocities up to 225 mph

L-858B Introduction

2.1.6 Dimensions

Table 2.1. Sign Heights

Type	Sign Size No.	Sign Face Height in (cm)	Legend Height in (cm)	Sign Style No.	Sign Class No.	Overall Mounting Height in (cm)
L-858B	4	48 (122)	40 (101.6)	2,3,5	1,2	58.2 (147.8)

Table 2.2. Sign Lengths - Inches (Centimeters)

Size No.	1 Module	2 Module	3 Module	4 Module
4	47.84 (121.5)	N/A	N/A	N/A

Note: Sign depth is 9.39 in (23.85 cm).

Figure 2.1. L-858 Sign Dimensions (Size 4/One-Module)

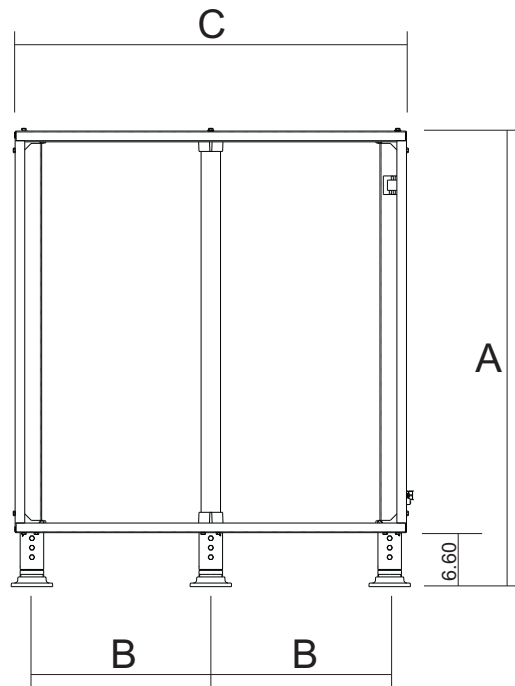

Table 2.3. L-858 Size 4 Sign Dimensions

Sign Size	A in. (cm)	B in. (cm)	C in. (cm)	Number of Lamps/ Modules
Size 4, 1-Module	55.69 (141.45)	21.87 (55.55)	47.84 (121.51)	4

2.1.7 Construction

Corrosion-resistant sign construction requires minimal maintenance.

- Aluminum housing
- Acrylic sign legend panels
- Stainless steel hardware
- Retroreflective sheeting

2.1.8 Electrical Supply

The L-858B (runway distance remaining) signs are internally lighted. The signs are connected to a series circuit using the appropriately-sized 50 or 60Hz L-830 isolation transformer(s).

Table 2.4. **Style No. Power Source**

2	4.8-6.6A (3-Step CCR)
3	2.8-6.6A (5-Step CCR)
5	5.5A (Dedicated sign circuit)

2.1.9 Sign Load and Transformer Requirements

Sign Size	Step	Max. Sign VA Load	Transformer	Transformer Load	Total CCR Load
4	3	115VA	200W	20VA	135VA
4	5	115VA	300W	30VA	145VA
4	5.5A only	115VA	150W	22.5VA	137.5VA

2.1.10 Spare Components

Description	Part No.
Floor flange (2-bolt)	62A2142
Floor flange, high wind speed (4-bolt)	62A2146
Frangible coupling, size 4	60A2678-40
Legend panel, retroreflective, size 4 ¹	44A6084-4110
Legend panel, blank, size 4	44A6084-4120
Tether	94A0054
LED sign power supply assembly	44A6631-96V

1. Customer to provide legend information.

2.1.11 Packaging Data

Signs are shipped with L-823 cord set, frangible couplings, and floor flanges—ready for installation.

Description	Gross Wt. (lb)	Gross Wt. (kg)	Dimensions of Carton (in)	Dimensions of Carton (cm)
Size 4, Module 1	122 ²	56 ²	62 x 52 x 13	158 x 132 x 33

2. Estimated weight

L-858B Introduction

3.0 Installation



WARNING

Read installation instructions in their entirety before starting installation.

- Refer to the FAA Advisory Circular AC 150/5340-26, Maintenance of Airport Visual Aids Facilities, for instructions on safety precautions.
- Observe all safety regulations. To avoid injuries, always disconnect power before making any wiring connections or touching any parts. Refer to FAA Advisory Circular AC 150/5340-26.
- Sign installation requires a flat mounting surface and the sign to be level to prevent legend panels from becoming distorted.
- Failure to install and level sign per the instruction manual will void the warranty

Each sign is furnished complete with mounting flanges for installation on a concrete pad, which is the recommended method of installation. Contact the SAS Sales Department for more information on sign installation hardware.

1. L-823 Cord Set (supplied with the sign)
2. Cable Clamp (supplied with the sign)
3. Floor Flange (supplied with the sign)
4. 2-inch Conduit Elbow (contractor supplied)
5. L-867 Blank Cover Plate with Gasket (purchased separately)
6. L-823 Extension Cord (purchased separately)
7. L-867 Base (purchased separately)
8. L-867 Base Plate (special - purchased separately)

Figure 3.1. Remote/Direct Mounting

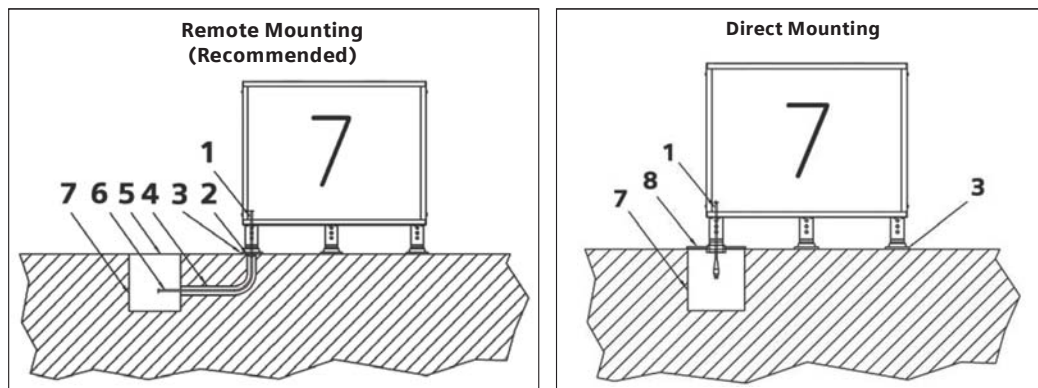

This section provides instructions for installing L-858 taxiway and runway signs. Refer to the airport project plans and specifications for the specific installation instructions and FAA AC 150/5340-18.

3.1 Unpacking

The equipment is shipped ready for installation. Handle equipment very carefully to prevent component damage. Unpack the carton upon receipt and check the contents and their condition. Note any exterior damage to the carton that might lead to detection of equipment damage.

If you note any damage to any equipment, file a claim with the carrier immediately. The carrier may need to inspect the equipment.

Cord Set Installation

3.2 Cord Set Installation

This subsection provides information for installing cord sets. It includes sign installation kit reference numbers for three power leg cord set installation locations and mounting configurations.

This subsection provides special cord set locations with parts and part numbers. See Figure 3-1 for the ordering code for the L-858 sign. Special cords set installation reference numbers are located in the ordering code.

3.2.1 Cord Set Installation Reference Number

Cord Set Exit Location #1

Figure 3.2 shows cord set location #1. Refer to Table 3.1 for cord set location #1 parts and part numbers.

Figure 3.2. Cord set Location #1 (Non-typical)

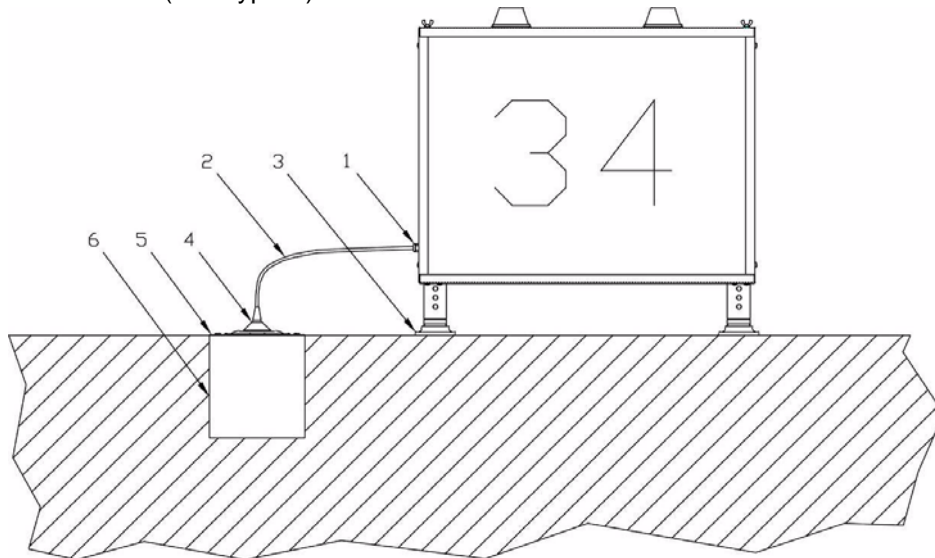

Table 3.1. Cord set Location #1 Parts

Item	Description	Supplier	Part Number	Note
1	Strain relief	Siemens Airfield Solutions	77A0156	A
2	Cord set 16/2 SOW 600 V	Siemens Airfield Solutions	Supplied with sign	B
3	Base flange	Siemens Airfield Solutions	62A2142 or 62A2146	A
4	Connector plug	Siemens Airfield Solutions	63B0550	C
5	2-in. (50.8-mm) L-867 base plate	Siemens Airfield Solutions	1932	C
6	12 x 24 in. (304.8 x 609.6 mm) L-867B base	Siemens Airfield Solutions	2124	C

Note: A: Shown for reference only. Part supplied with sign.
 B: Signs supplied with the following length external to the sign: Size 1 = 47 in. Size 2 = 41 in. Size 3 = 35 in. Size 4 = 18 in. Size 5 = 35 in. Any other external length requires a separate line on the purchase order specifying the external length required.
 C: Requires a separate line item on the purchase order.

Cord set Exit Location #2

Figure 3.3 shows cord set location #2. Refer to Table 3.2 for cord set location #2 parts and part numbers.

Figure 3.3. Figure 3-2 Cord set Location #2 (Non-typical)

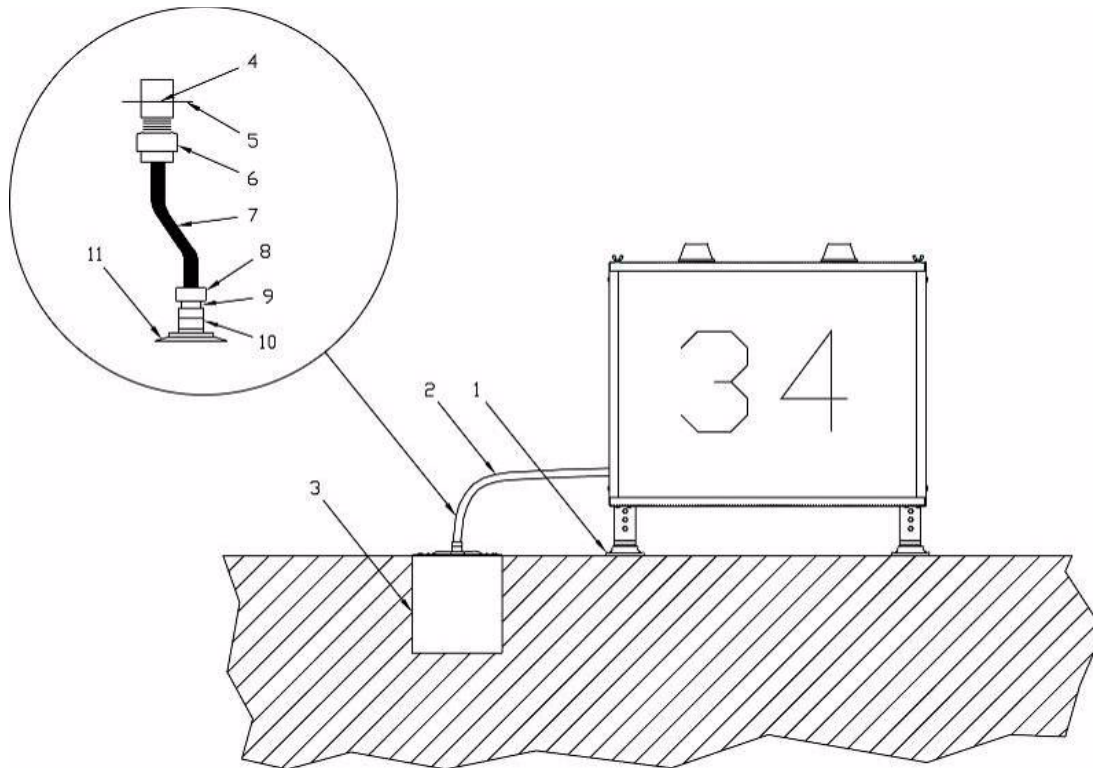

Table 3.2. Cord set Location #2 Parts

Item	Description	Supplier	Part Number	Note
1	Base flange	Siemens Airfield Solutions	62A2142 or 62A2146	D
2	L-823 cord set 16/2 SOW 600 V	Siemens Airfield Solutions	Supplied with sign	B
3	12 x 24 in. (304.8 x 609.6 mm) L-867B base	Siemens Airfield Solutions	2124	C
7	Flexible conduit	Contractor	Not applicable	A
10	Frangible coupling	Siemens Airfield Solutions	62B0499	C
11	2 in. (50.8 mm) L-867 base plate	Siemens Airfield Solutions	1932	C

Note: A: Refer to Table 3.3 for flexible conduit connectors.
 B: Signs supplied with the following length external to the sign: Size 1 = 47 in. Size 2 = 41 in. Size 3 = 35 in. Size 4 = 18 in. Size 5 = 35 in. Any other external length requires a separate line on the purchase order specifying the external length required.
 C: Requires a separate line item on purchase order.
 D: Shown for reference only. Part supplied with sign.

Table 3.3. Flexible Conduit Connectors

Item	Description	Supplier
4	3/4-inch (44.45 mm) diameter hole	Siemens Airfield Solutions
6	1-1/4 inch (31.75 mm) flexible conduit male connector	Contractor
7	1-1/4 inch (31.75 mm) flexible conduit	Contractor
8	1-1/4 inch (31.75 mm) flexible conduit male connector	Contractor
9	1-1/2 x 1-1/4-in. (38.1 x 31.75-mm) hex reducer bushing	Contractor

Cord Set Installation

Cord set Exit Location #3

Figure 3.4 shows cord set location #3. Refer to Table 3.4 for cord set location #3 parts and part numbers.

Figure 3.4. Cord set Location #3 (Standard)

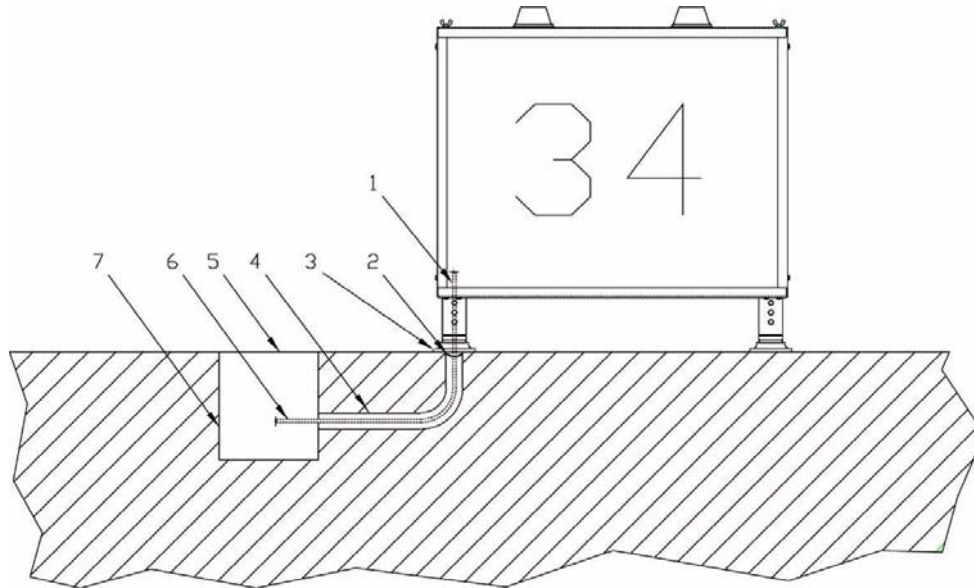

Table 3.4. Cord set Location #3 Parts

Item	Description	Supplier	Part Number	Note
1	Cord set 16/2 SOW 600 V	Siemens Airfield Solutions	Not applicable	
2	Cable clamp	Siemens Airfield Solutions	60A2851	B
3	Base flange	Siemens Airfield Solutions	62A2142 or 62A2146	A
4	2-in. (50.8 mm) rigid conduit	Siemens Airfield Solutions	Not applicable	
5	3/8 inch (9.53 mm) thick base plate	Siemens Airfield Solutions	1000-6	
6	8-foot (2.44 m) extension cord	Siemens Airfield Solutions	73A0109-8	C
7	12 x 24 in. (304.8 x 609.6 mm) L-867B base	Siemens Airfield Solutions	2124	C
NS	Gasket	Siemens Airfield Solutions	2052	B, D

Note: A: Shown for reference only. Part supplied with sign.
 B: Requires a separate line item on purchase order.
 C: Refer to *Cord sets and Extension Cords* in this section for extension cords available if different extension cord length is required.
 D: Gasket is sold separately.

Cord Set Installation

Cord set Exit Location #4

Figure 3.5 shows cord set location #4. Refer to Table 3.5 for cord set location #4 parts and part numbers.

Figure 3.5. Cord set Location #4 (Standard)

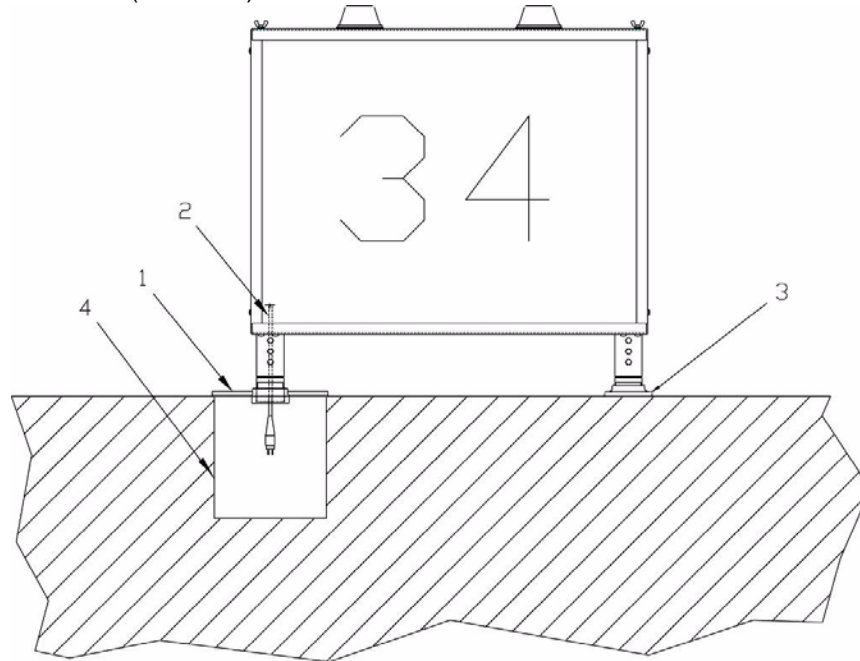

Table 3.5. Cord set Location #4 Parts

Item	Description	Supplier	Part Number	Note
1	12-inch heavy base plate, 2-1/2 NPT	Siemens Airfield Solutions	1832-BSPLT	B
2	Cord set 16/2 SOW 600 V	Siemens Airfield Solutions	73A0107/72	A
3	Base flange	Siemens Airfield Solutions	62A2142 or 62A2146	A, C
4	12 x 24 in. (304 x 610 mm) L-867B base	Siemens Airfield Solutions	2124	B

Note: A: Shown for reference only. Part supplied with sign.
 B: Requires a separate line item on the purchase order.
 C: Remove the base flange shipped with the sign when the leg is screwed into the base plate.

Cord Set Installation

3.2.2 Cord set and Extension Cords

See Figure 3.6. Refer to Table 3.6 for cord set and extension cord types. Refer to Table 3.7 for cord set and cord parts.

Figure 3.6. L-823 Cord set and Extension Cords

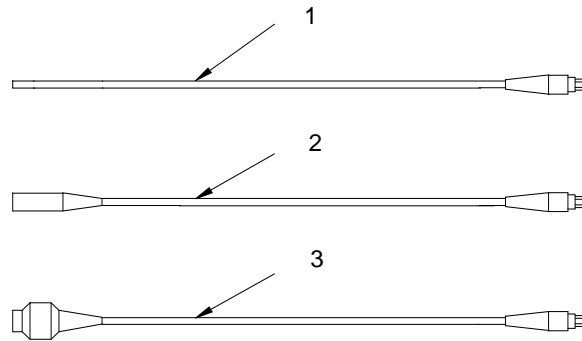

Table 3.6. Cord set and Extension Cord Length

Type	Part Number	Receptacle Style	Plug Style	Standard Length	Wire
1	73A0107-X	Not applicable	Type II, Class A, Style 1	4 ft. (1.22 mm) 6 ft. (1.83 mm)	16/2
2	73A0108-X	Type II, Class A, Style 7	Type II, Class A, Style 1	8 ft. (2.44 mm)	16/2
3	73A0109-X	Type II, Class A, Style 7	Type II, Class A, Style 1	8 ft. (2.44 mm)	16/2

Table 3.7. Cord set and Extension Cord Parts

Item	Description	Part Number	Note
1	L-823 cord set, 16/2 wire		A, B
	Cord set, standard size 4 ft. (1.22 mm)	73A0107-48	
	Cord set, standard size 6 ft. (1.83 mm)	73A0107-72	
2	L-823 cord set extension cord, 16/2 wire, standard size 8 ft. (2.44 mm)	73A0108-8	A, C
3	L-823 cord set extension cord, 16/2 wire, standard size 8 ft. (2.44 mm)	73A0109-8	A, D

Note: A: Other sizes require special order.
 B: A minimum of thirty inches (762 mm) of cord set length is required for internal sign connections. Usable exterior cord set length is equal to the cord set length minus a minimum of 30 inches (varies with sign size and cord set exit location).
 C: Receptacle may be connected to plug on 73A0107-X, 73A0109-8 cord set, or standard 31-inch (787.4 mm) L-823 cord set.
 D: Receptacle must be connected to plug on, Plug Type II, Class A, and Style 1, supplied with the sign.

3.3 General Guidelines



WARNING

- Signs must be grounded to a true earth ground. Failure to observe this warning may result in personal injury, death, or equipment damage.
- When installing signs, follow the guidelines covered in FAA AC 150/5340-30, Fig 126 for mounting pad design. Also see the following subsections for detailed information on sign pad and leveling of the sign.
- FAILURE TO INSTALL AND LEVEL THE SIGN AS DESCRIBED IN THE VARIOUS SUBSECTIONS BELOW WILL VOID THE WARRANTY

- Mount the signs on a concrete slab or concrete pedestals
- Do not allow concrete edges to protrude above grade.
- Provide power to the signs through breakaway cable connectors installed within the frangible coupling portion of the sign's mounting legs.
- Install auxiliary equipment, such as isolation transformers, in a light base embedded in the ground.

3.3.1 Overall Mounting Height

Install signs so that the overall height above the surrounding ground of the sign assembly, including mounting supports, does not exceed heights given in Table 2-6 and the clearances of aircraft wings as specified in AC 150/5340-18. The sign must provide 12 inches (304.8 mm) of clearance between the top of the sign and any part of the most critical aircraft using, or expected to use, the airport when the aircraft's wheels are at the pavement edge. For overall mounting height, refer to AC 150/5345-44.

3.3.2 Sign Orientation

When orienting signs follow the guidelines below

- Orient the sign so that the face is perpendicular to the centerline of the taxiway or runway.

Note: Check site plans and specifications for the location of the power leg (leg where the L-823 cord set is located) in reference to the L-867 light base. Typically, the L-867 light base is immediately under the power leg or is at the same end, but not under the power leg. Siemens Airfield Solutions' signs are shipped with the sign product label attached to the sign end where the power leg is located. In addition, verify that the sign legend is orientated correctly to the taxiway or runway per the site plans when the sign is installed on the pad. If the sign legend location is not correct, then the panels must be removed and reinstalled in the sign in the correct location.

- For special situations refer to FAA AC 150/5340-18 for the correct orientation.

3.3.3 Sign Distance from Pavement Edge

Refer to Table 3.8 for the distance of signs from the pavement edge. Refer to AC 150/5340-18 for more information on the location of different types of taxiway signs.

Table 3.8. Recommended Sign Distance from Pavement Edge

Sign Size	Distance from Pavement ft.	Distance from Pavement m
4	50–75	15.2–22.9

3.3.4 Sign Installation on Concrete Pad

Note: Follow site plans and specifications for concrete dimensions.

Concrete Pouring

See FAA AC 150/5340-30, Figure 126, for concrete base design.

To pour a concrete pad, perform the following procedure:

1. Determine the sign size and module.
2. Pour your concrete pad according to the following requirements:

General Guidelines

- A minimum of 30 inches (762 mm) wide, extending a minimum of 6 inches (152.4 mm) beyond the end of the supports. The sign pad needs to be flat and level in the area where the sign mounting flanges are located. See FAA AC 150/5345-30, Figure 126. The mounting floor flange is nominally 5.0 wide x 7.50 long and the area beyond the flange can be tapered to the outside edge of the concrete pad to provide for pad drainage.
 - A minimum of 4 inches (101.6 mm) depth, extending below the frost line to prevent frost heave.
 - Reinforce according to site plans and specifications
3. Install a minimum of one 12-inch (304.8 mm) L-867B power base (1) according to the following guidelines:
- Install the base close to the sign in or near the concrete pad to provide easy access to the isolation transformer.

Note: When installing the base in the concrete pad, hold the L-867 base firmly in place during construction of the pad so that the upper surface of the base flange is level within ± 2 degrees and not more than 3/8 inch (9.525 mm) above the concrete surface.

- All other bearing surfaces on the pad for additional flange supports should be kept in the same horizontal plane as the L-867 base flange. The pad area where the sign mounting flanges will be located is to be flat **with no taper** to ensure that the sign will set level to prevent uneven loading on the frangible couplings. See FAA AC 150/5340-30, Figure 126 for pad design.
- For the Mode 1 and 2 signs

Before the concrete sets, install two 1/2–13 anchor bolts into the concrete pad. The bolt hole centerline is on a 6-inch diameter bolt circle, 180 degrees apart as shown. Bolt slots are 0.62-inches wide x 1.0 long. Overall width of flange is 5.0 inches and overall length is 7.5 inches. Bolts should be located perpendicular to the sign face.

Figure 3.7. Mode 1 and 2 Frangible Couplings



- For the Mode 3

Before the concrete sets, install four 1/2–13 anchor bolts into the concrete pad. The bolt holes are on an 8-inch-diameter bolt circle, 90 degrees apart as shown. Holes are 0.62-inch diameter. Overall size is 7.75 x 7.75 inches. Bolts should be located perpendicular to the sign face.

Figure 3.8. Mode 3 Frangible Couplings

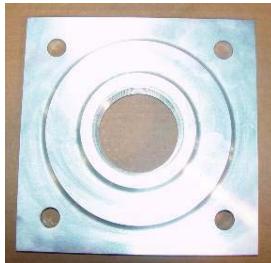

Note: A customer-supplied setting fixture is recommended to hold the bolts in position while the concrete sets. Anchor bolts must be a minimum of 1.25 inches (31.75 mm) above the top surface of the concrete pad to attach the mounting bases. Hilda quick bolts are recommended for installing the flanges after the concrete sets.

3.3.5 Sign Mounting

Note: Signs are totally assembled at the factory and are ready for direct installation. Mounting flanges may be removed to lubricate the threads of the frangible coupling with anti-seize compound before installing sign.

If male L-823 connector is routed through a leg, slide frangible coupling over male connector and insert into female connector in base plate, and then screw frangible coupling into base plate.

To mount the sign onto the concrete pad to insure the assembly is flat, perform the following procedure:

1. When the sign is ready to be bolted to the concrete pad set the sign assembly on the concrete pad and position the sign over the anchor bolts. Hand-tighten the bolts or nuts to fasten the mounting flanges to the concrete pad.
2. **To insure that the sign assembly is mounted flat on the concrete pad**, first loosen all three hex set screws found on each frangible coupling that are installed on the sign. See Figure 3.9. Once all the hex screws are loosened each of the sign legs will float free inside the frangible coupling that is screwed into the mounting flange. Second, use a bubble, digital, or laser level to verify that the assembly is flat and level. Adjustments to make the assembly flat and level can be made by raising or lowering one end of the sign assembly to make the assembly flat and level.

Note: Once the assembly is flat it may be necessary to block-up or hold the assembly in the flat position until all of the hex set screws can be re-tightened on each of the frangible couplings to secure the sign leg to the coupling. Once the sign is flat and level finish tightening the mounting bolts to their correct torque value.

If the sign pad is tapered in the area when the mounting flanges are located shims may need to be placed under the mounting flanges to ensure that the coupling frangibility characteristics are the same for each coupling. If in doubt, contact Siemens Airfield Solutions Engineering.

Figure 3.9. Sign Frangible Coupling



CAUTION

- Sign frangible couplings are uniquely designed for use on the sign size stamped on the coupling and can only be used for that particular size sign. If couplings must be replaced, make sure the sign size on the couplings matches the size sign on which they are to be installed.

3. Connect an AWG 12 (minimum) ground wire to the earth ground lug on the bottom of the sign. Refer to Figure 3.11 for electrical connections for series circuit installation.



CAUTION

- Lock out power before making any electrical connections. Failure to observe this warning may result in personal injury, death, or equipment damage.

4. Install optional tether. Refer to *Optional Tethers* in this section.
5. Plug the cord set into the sign and the transformer.
6. Reinstall panels (if removed) and top lid (if removed).

General Guidelines

3.3.6 Wiring

Refer to Figure 3.11 for wiring diagrams.

When installing cable, follow the guidelines below.

- Install all cable for direct earth burial or for placement in duct according to Item 108 or Item 110 of AC 150/5370-10 as appropriate.
- Operate the signs as a part of a series lighting system. The signs are connected into the series circuit by means of an isolation transformer, see Section 2.1.9, "Sign Load and Transformer Requirements", on page 2-3. If installation is to be independent of other lighting circuits, use current edition of AC 150/5340-24, *Runway and Taxiway Edge Lighting System*, for system reference and material needs.

3.3.7 Earth Ground Lug



WARNING

- Signs must be properly grounded to true earth ground. Failure to observe this warning may result in personal injury, death, or equipment damage.



Attach the earth ground lug. The earth ground lug is located on the outside frame of the sign to permit easy connection of an AWG 12 (minimum) earth ground wire to the sign. If necessary, you may remove the ground lug from the outside and place it on the inside.

3.3.8 Optional Tethers

See Figure 3.10. Tethers are shipped installed on the sign sales order. Location and quantity of the tether are determined when the sales order is placed.

Note: In the tether installation procedure below, the customer supplies the mounting hardware to attach one end of the tether to the concrete pad. The customer also supplies the expansion anchor for the bolt.

Figure 3.10. Installing Optional Tether

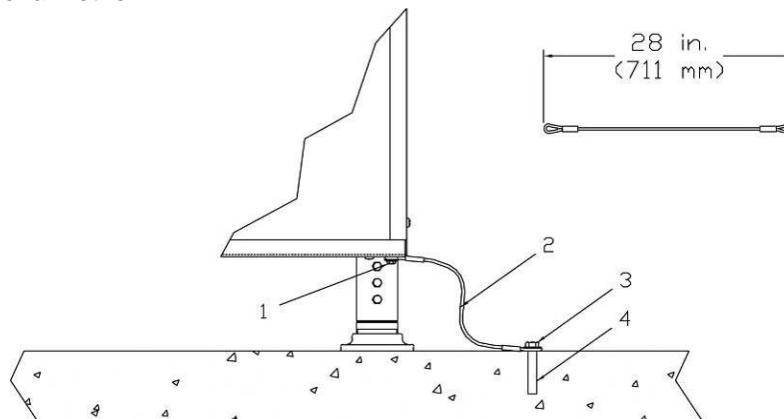

1. Existing 5/16-18 x 3/4 in. Bolt
 2. Tether
 3. Mounting Hardware Attached to Expansion Anchor
 4. Expansion Anchor for Bolt
5. To attach a tether, install the customer-supplied mounting hardware (3) to attach the tether to the expansion anchor (4) on the concrete pad.

Figure 3.11. Wiring Diagram

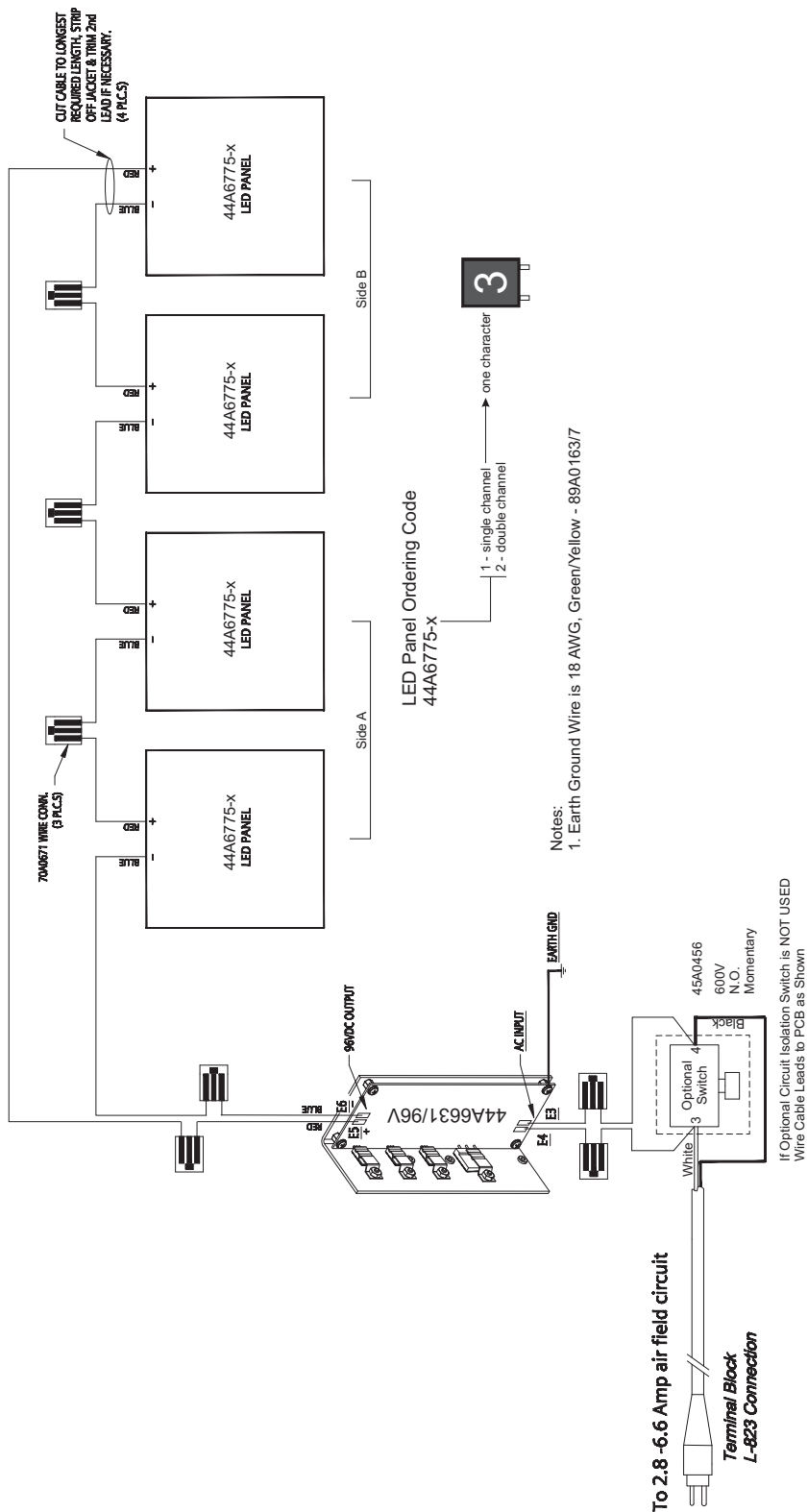

43A3372

General Guidelines

4.0 Maintenance

This section provides preventive maintenance for L-858 signs.

To keep the L-858 taxiway and runway signs operating efficiently, follow a preventive maintenance schedule. Refer to Table 4.1.

Table 4.1. L-858 Taxiway and Runway Sign Maintenance

Interval	Maintenance Task	Action
Daily	Check for burned-out LED boards.	Check circuit operation.
Monthly	Check for dirty panels.	Clean with mild soap and water.
	Check for vegetation covering panel.	Remove vegetation.
Semi-Annually	Check for loose wire connections.	Tighten wires.
	Check for cracked or deteriorated wire.	Replace wire.
Annually	Check for paint flaking off.	Repaint.
	Check for panels yellowing.	Clean with Formula 409 or similar cleaning agent.
	Check for deteriorated gaskets.	Replace gaskets.



CAUTION

This equipment may contain electrostatic sensitive devices.

- Protect from electrostatic discharge.
 - Electronic modules and components should be touched only when this is unavoidable e.g. soldering, replacement.
 - Before touching any component of the cabinet you should bring your body to the same potential as the cabinet by touching a conductive earthed part of the cabinet.
 - Electronic modules or components must not be brought in contact with highly insulating materials such as plastic sheets, synthetic fibre clothing. They must be laid down on conductive surfaces.
 - The tip of the soldering iron must be grounded.
 - Electronic modules and components must be stored and transported in conductive packing.
-

Replacing the Power Supply

4.1 Replacing the Power Supply

1. Remove the three #8-32 screws with lock washers installed in the PEM nuts of the power supply. Retain for future use. See Figure 4.1
2. Locate the three threaded PEM nuts installed in the mounting bracket of the Power Supply and align the PEM nuts with the mating holes in the end panel of the sign.
3. Insert the three #8-32 screws with lock washers through the holes in the end panel and screw them into the PEM nuts. When tightening the screws make sure the Power Supply is seated flat against the side of the sign.



CAUTION

- Be careful that the screws do not bind as you are tightening.
This may give the impression that the power supply is firmly mounted when it is not!

4.1.1 Wiring the Power Supply

See the Wiring Diagram, Figure 3.11.

The Power Supply has wires with a splice connector with spring loaded terminals on the ends. To connect the wires, pull up on the orange lever over the terminal you want to install a wire into with a flat head screwdriver or your finger. This will open the terminal. Insert the stripped end of the wire completely into the terminal and press the orange lever back toward the connector body. If any of the stripped wire is extending beyond the edge of the connector, remove the wire and trim off some of the stripped wire length. Verify also that the connector is not clamping onto the wire insulation, preventing electrical contact.

1. Locate the input power wires (from the L-830 secondary). Connect these wires to the Power Supply terminals labeled "AC INPUT". This is the isolated 6.6A input. Polarity does not matter.
2. Locate the wires that connected the DC Supply to the LED panels. Connect these wires to the Power Supply terminals labeled "96 VDC". You will need to cut off the "Fast-On" terminals and strip off the wire insulation before inserting into the terminal. This is a DC voltage, and polarity does matter.
3. Verify that the sign wiring matches the Wiring Diagram, Figure 3.11.
4. You are now ready to apply power to the sign.

Figure 4.1. The LED Power Supply

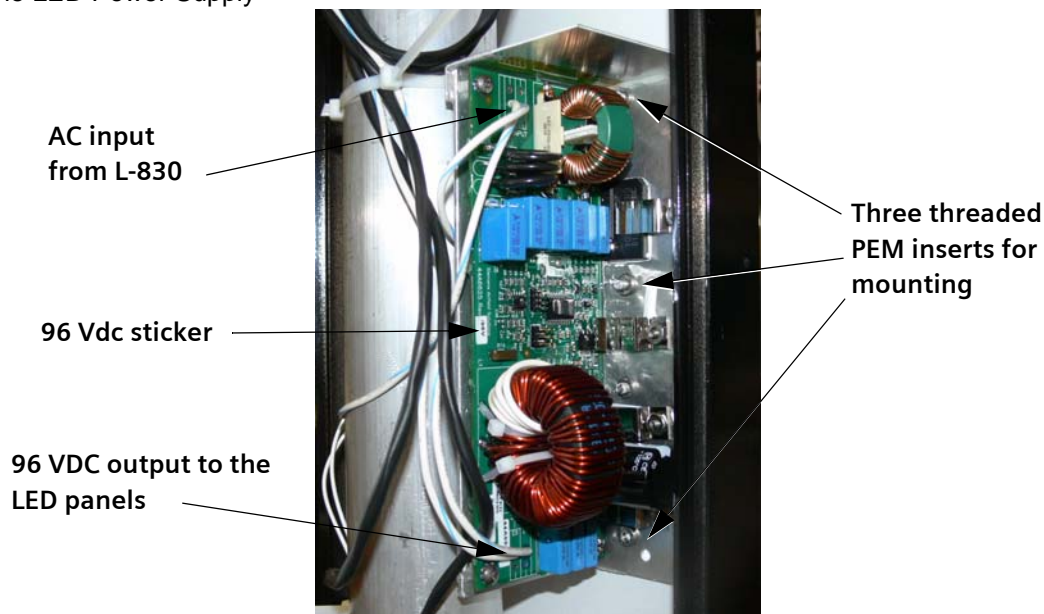



WARNING

The only visual difference between and 240VDC Fluorescent Power Supply and this 96 VDC is a sticker in the center of the board, labelled (96Vdc)



This is the **WRONG** power supply!
This is a 240 Vdc Power supply -- **DO NOT USE** on a LED sign!



This is the **CORRECT** power supply!
Labelled 96 Vdc

4.2 Replacing an LED Panel

Short the power to the sign. Open the panel by removing the top cover. Remove the sign face. Disconnect the power connector from the LED panel.

Remove the pop-rivets at the top and bottom of the panel. Note this will loosen both the front and back panels, so take care not to drop one. Replace the faulty panel and replace the pop rivets. Close the panel and restore power to the sign.

Figure 4.2. Sign Panel Interior - Single and Double Channel Shown

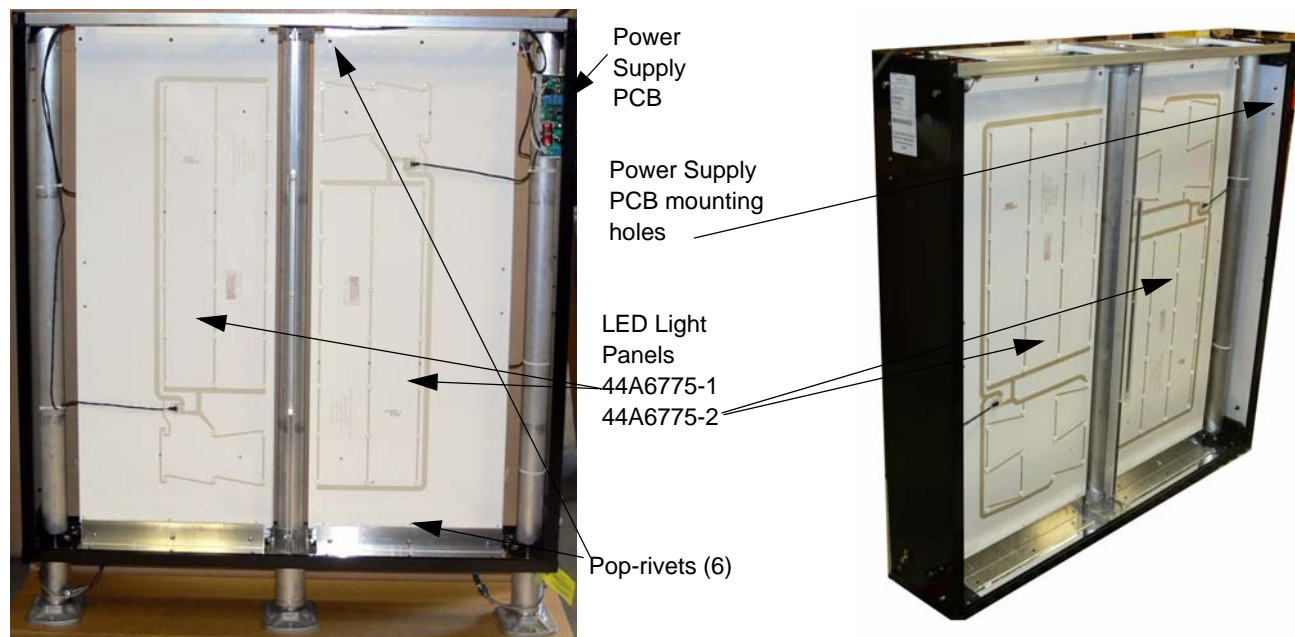

Note: Single Channel Panel has 3 columns of LEDs and the Double Channel Panel has 4 columns of LEDs. A single channel side will have just one character (see front cover) and the double has two characters.

*Troubleshooting***4.3 Troubleshooting**

This section provides troubleshooting information for the L-858 taxiway and runway signs. The information covers only the most common problems. If you cannot solve the problem with the information given here, contact your local Siemens Airfield Solutions representative for help.

Problem – LED Signs	Possible Cause	Corrective Action
1. All lamps are out or not functioning correctly.	Loose wires or connections	Tighten or replace wires. Check L830 for out of phase condition – see page 3-17
	CCR circuit-shortcd	Check circuit. Refer to AC 150/5340-26.
	Isolation Switch Stuck Closed	Check the Sign isolation switch for proper operation.
	Power Supply Fault	Check the input current and output voltage (96Vdc) for the power supply.
2. Lamps are too bright or are dim.	Power supply fault or CCR is not operation correctly	Check the CCR's output current. Check the input current and output voltage (96Vdc) for the power supply.

5.0 Parts/Ordering Codes

To order parts, call Siemens Airfield Solutions Customer Service or your local Siemens Airfield Solutions representative. Use this four-column parts list, and the accompanying illustration, to describe and locate parts correctly.

This subsection describes how to use the illustrated parts list covered later in this section. It does not provide the actual parts list.

The Part Number column gives the Siemens Airfield Solutions part number in numerical order.

The Description column gives the part name, as well as its dimensions and other characteristics when appropriate.

Part Number	Description	Quantity	Note
xxxxxxx	Assembly	1	A
xxxxxxx	Part	1	
xxxxxxx	Part or Assembly	2	
xxxxxxx	Assembly	1	
NOTE A			

The Quantity column contains the quantity required per unit, assembly, or subassembly. The code AR (As required) is used if the part number is a bulk item ordered in quantities or if the quantity per assembly depends on the product version or model.

The Note column contains letters that refer to notes at the end of each parts list. Notes contain special ordering or product/part version information.

Parts and Ordering Codes

5.1 Parts and Ordering Codes

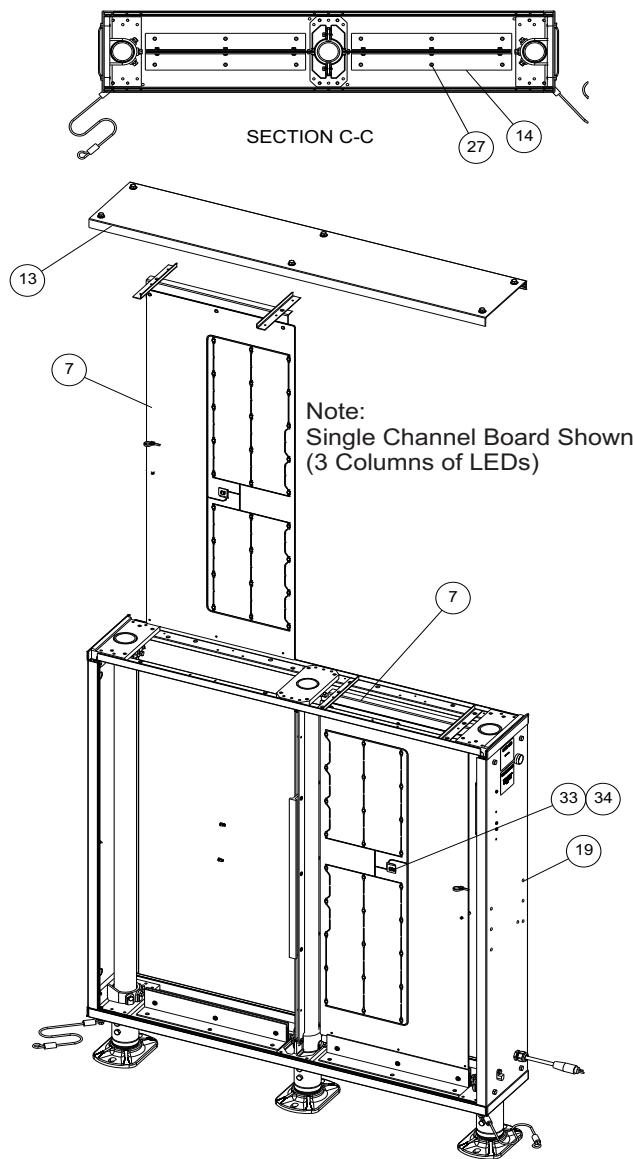

Note:
Single Channel Board Shown
(3 Columns of LEDs)

LED Panel Ordering Code
44A6775-x

1 - single channel → one character
2 - double channel



ITEM NO.	PART NUMBER	DESCRIPTION
2	42A0577	L858 LED SIGN LABEL
3	44A6084-4110	LEGEND PANEL ASSY, SIZE 4, STIMSONITE
3	44A6084-4111	LEGEND PANEL ASSY, SIZE 4, STIMSONITE HIGH WIND
4	44A6120-411	SIGN SIDE PNL ASSY SZ4, LOW COST
5	44A6121-41	SIGN INTERMED SUPP ASSY SIZE 4, LOW COST
6	44A6631-96V	LED SIGN PWR SUPPLY ASSY
7	44A6775-1	LED PANEL ASSY - SINGLE NUMBER (3 columns of LEDs)
7	44A6775-2	LED PANEL ASSY - DOUBLE NUMBER (4 columns of LEDs)
8	45A0456	SWITCH,PB.NO.10A,600VAC,MOMENTARY FLUSH
9	60A2661-41U0	L858 SIGN SUPPORT RAIL SIZE 4, LOW COST
10	60A2664-4100	L858 BOTTOM PANEL
11	60A2678-40	SIGN FRANGIBLE FITTING
11	60A2678-41	SIGN FRANGIBLE FITTING - HIGH WIND
12	60A2685-30	SIGN INT.PANEL SUPPORT SZ3&4
13	60A2968-4110	FLUOR. SIGN TOP LID SZ4 1MOD END-END
14	60A3347	SUPPORT ASSY LED PANEL
15	61A0415	1/4" PUSH MOUNT WIRE TIE
16	62A2142	SIGN BASE
17	63A1015	LIQUID TIGHT KNOCKOUT SEAL
18	63A1065	1/4 PUSH TYPE HOLE PLUG BLACK
19	63A1091	3/16 PUSH TYPE HOLE PLUG BLACK
20	64A0076-12	5/16-18 X 3/4 HX BOLT
21	64A0076-16	5/16-18 X 1 HX BOLT
22	64A0173-10	1/4-20 X 5/8 HX HD
23	64A0176/8	3/8-16 X 1/2 HX HD
24	64A0191-6	8-32 X 3/8 LONG PAN HD PHIL
25	65A0015/24	1/4-20 HX NUT, SS
26	65A0526-1	POP RIVET 3/16 X 1/2 - 5/8 GRP
27	65A0528-1	BLIND RIVET 5/32 1/8-1/4 GRIP
28	66A0015/26	5/16 FLATWASHER
29	66A0026/15	#8 SPLIT LOCKWASHER
30	66A0026/24	1/4 SPLIT LOCKWASHER
31	66A0259-6	#8 NYLON WASHER
32	67A0094	LOCTITE 262
33	70A0730	MOLEX RECEPTACLE 43650-0200
34	70A0731	MOLEX FEMALE TERMINAL 43030-0007
35	72A0010	GROUND LUG
36	73A0107-72	CORDSET, 16/2 FAA CL A, TYPE II STYLE 1
37	77A0156	COMPRESSION FITTING 1/2" NPT
38	89A0002-9	22AWG WHITE - 14FT
39	89A0073-1	18AWG 200C WHITE - 2FT
40	89A0194	18AWG 105C WHITE - 2FT
41	RM0497	SEAL CC NEOPR. .25T X.5WX8.1LG.
42	62A2146	HIGH WIND SIGN BASE
43	77A0149	LOCKNUT 1/2" NPT
44	94A0054	L858 TETHER 3/16", 28" LG.

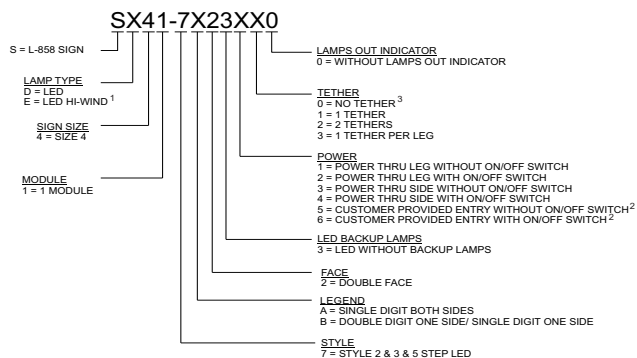

Customer to provide legend information and power connection side. It is important to match power cord exit location with legend side.

Ordering Code Notes:

1. Use high wind signs in locations where actual wind speed exceeds FAA specific cations. High wind signs are tested to a minimum wind load of 327 mph as recommended by FAA technical paper DOT/FAA/AR-TN00/32: Evaluation of Wind-Loading on Airport Signs. High wind signs require four anchor bolts per floor flange.
2. Cord set coiled up inside. Customer provides entry hole.
3. Not ETL Certified

Parts and Ordering Codes

Figure 5.1.

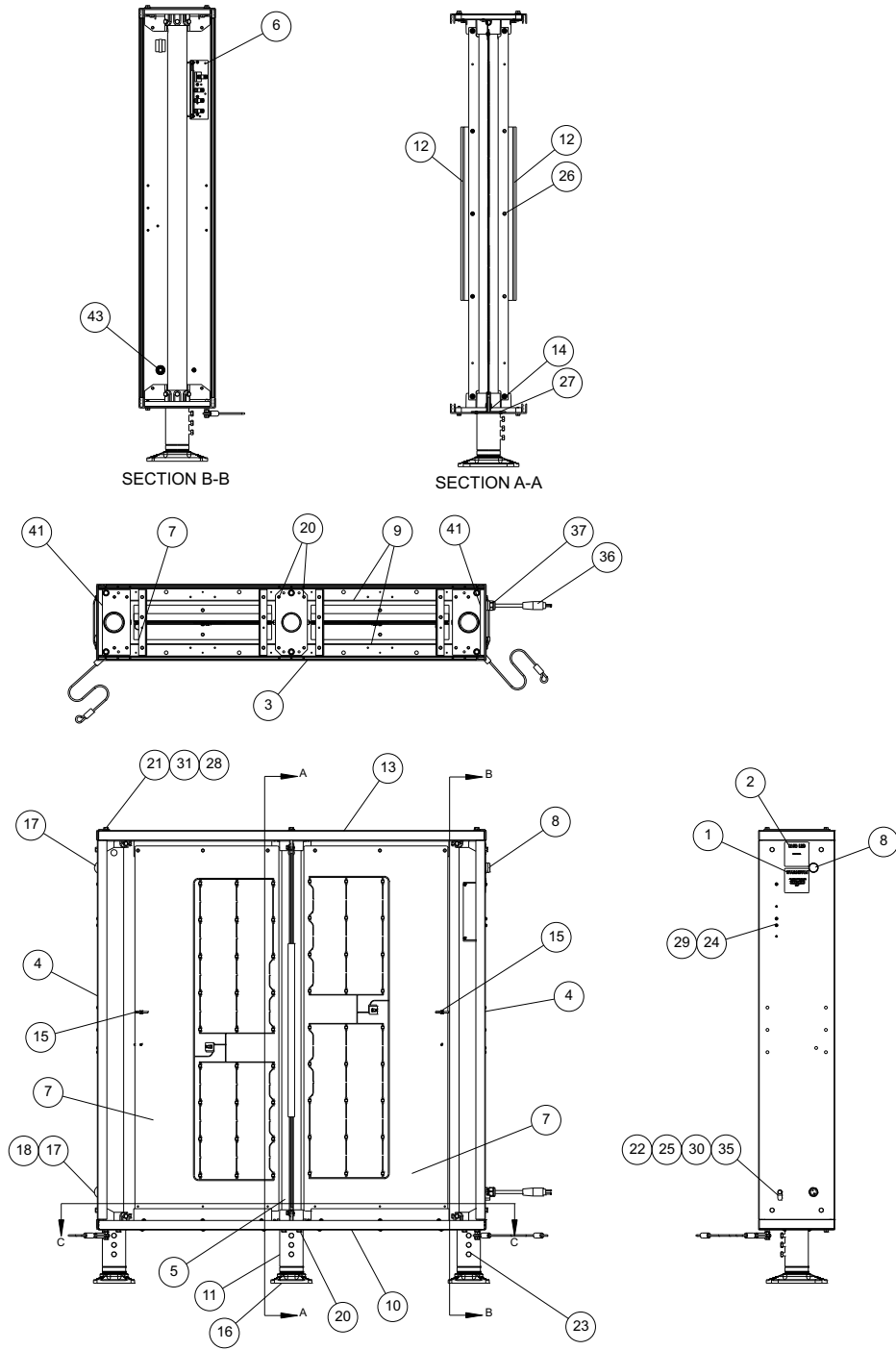

Parts and Ordering Codes

Figure 5.2.

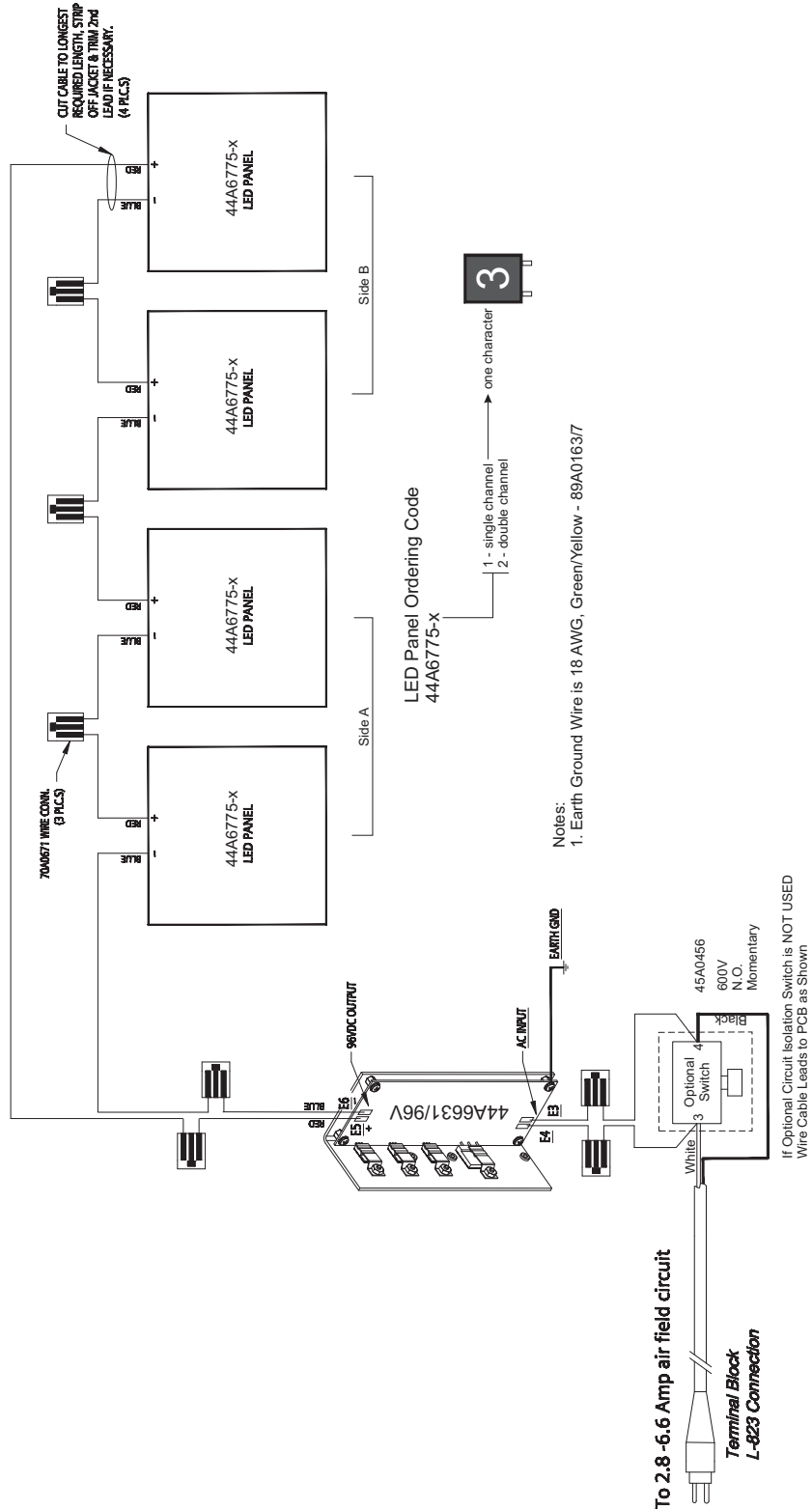

43A3372



Siemens Airfield Solutions
977 Gahanna Parkway
Columbus, Ohio 43230

1-800-545-4157
info.sea@siemens.com

www.usa.siemens.com/airfield-solutions

2008 Siemens Energy & Automation, Inc. All Rights Reserved.
Siemens is a registered trademark of Siemens AG. Product names mentioned may be trademarks or registered trademarks of their respective companies. Specifications are subject to change without notice.

Printed in USA